



# Product Specification

AU OPTRONICS CORPORATION

Preliminary Specifications

Final Specifications

<b>Module</b>	15.0" WXGA Color TFT-LCD
<b>Model Name</b>	M150EW01 V0(non-Glare)

<b>Customer</b>	<b>Date</b>
_____	_____
<b>Checked &amp; Approved by</b>	
_____	_____

<b>Approved by</b>	<b>Date</b>
_____	_____
<b>Prepared by</b>	
_____	_____

Note: This Specification is subject to change without notice.

Desktop Display Business Group /  
AU Optronics corporation



## Contents

<b>1. Handling Precautions .....</b>	<b>4</b>
<b>2. General Description.....</b>	<b>5</b>
2.1 General Specification.....	5
2.2 Optical Characteristics.....	6
<b>3. Functional Block Diagram.....</b>	<b>10</b>
<b>4. Absolute Maximum Ratings .....</b>	<b>11</b>
4.1 Absolute Ratings of TFT LCD Module.....	11
4.2 Absolute Ratings of Backlight Unit.....	11
4.3 Absolute Ratings of Environment .....	11
<b>5. Electrical characteristics .....</b>	<b>12</b>
5.1 TFT LCD Module .....	12
5.2 Backlight Unit .....	13
<b>6. Signal Characteristic .....</b>	<b>.....</b>
6.1 Pixel Format Image .....	.....
6.2 The input data format .....	.....
6.3 Signal Description/Pin Assignment.....	.....
6.4 Interface Timing .....	.....
<b>7. Connector Description.....</b>	<b>15</b>
7.1 TFT LCD Module .....	15
7.2 Backlight Unit .....	15
7.3 Signal for Lamp connector .....	15
<b>8. Reliability Test .....</b>	<b>16</b>



# Product Specification

AU OPTRONICS CORPORATION

## Record of Revision

Version and Date	Page	Old description	New Description	Remark
0.1 2007/08/13	All	First Edition for AUO internal		



## 1. Handling Precautions

- 1) Since front polarizer is easily damaged, pay attention not to scratch it.
- 2) Be sure to turn off power supply when inserting or disconnecting from input connector.
- 3) Wipe off water drop immediately. Long contact with water may cause discoloration or spot.
- 4) When the panel surface is soiled, wipe it with absorbent cotton or other soft cloth.
- 5) Since the panel is made of glass, it may break or crack if dropped or bumped on hard surface.
- 6) Since CMOS LSI is used in this module, take care of static electricity and insure human earth when handling.
- 7) Do not open or modify the Module Assembly.
- 8) Do not press the reflector sheet at the back of the module to any directions.
- 9) In case if a Module has to be put back into the packing container slot after once it was taken out from the container, do not press the center of the CCFL reflector edge. Instead, press at the far ends of the CCFL Reflector edge softly. Otherwise the TFT Module may be damaged.
- 10) At the insertion or removal of the Signal Interface Connector, be sure not to rotate nor tilt the Interface Connector of the TFT Module.
- 11) After installation of the TFT Module into an enclosure, do not twist nor bend the TFT Module even momentary. At designing the enclosure, it should be taken into consideration that no bending/twisting forces are applied to the TFT Module from outside. Otherwise the TFT Module may be damaged.
- 12) Cold cathode fluorescent lamp in LCD contains a small amount of mercury. Please follow local ordinances or regulations for disposal.
- 13) Small amount of materials having no flammability grade is used in the LCD module. The LCD module should be supplied by power complied with requirements of Limited Power Source (IEC60950 or UL1950), or be applied exemption.
- 14) The LCD module is designed so that the CCFL in it is supplied by Limited Current Circuit (IEC60950 or UL1950). Do not connect the CCFL in Hazardous Voltage Circuit.



# Product Specification

AU OPTRONICS CORPORATION

## 2. General Description

M150EW01 V0 is a Color Active Matrix Liquid Crystal Display composed of a TFT LCD panel, a driver circuit, and backlight system. The screen format is intended to support the WXGA (1280(H) x 720(V)) screen and 262k colors (RGB 6-bits data driver). All input signals are LVDS interface compatible. Inverter of backlight is not included.

## 2.1 General Specification

The following items are characteristics summary on the table at 25°C condition:

Item	Unit	Specification	Remark
Screen Diagonal	[mm]	381	15.0 inch
Active Area	[mm]	332.16(H) × 186.84(V)	
Maximum Resolution	-	1280x3(RGB) x 720	
Pixel Pitch	[mm]	0.2595	
Pixel Arrangement	-	R.G.B. Vertical Stripe	
Display Mode	-	TN, Normally White	
White Luminance (Center)	[cd/m <sup>2</sup> ]	200*	
Contrast Ratio	-	400:1	
Optical Response Time	[ms]	8*	Tr+Tf
Color Saturation	%	45%	
Nominal Input Voltage VDD	[voltage]	3.3	
Power Consumption	[watt]	14.4*	2 CCFL
Weight	[grams]	1150*	
Physical Size	[mm]	354.1 (H) x 227.4 (V) x 12 (D)*	
Electrical Interface	-	1channel LVDS	
Support Color	-	16.7M (6bit+Hi-FRC)	
Temperature Range	[°C]	0 ~ +50	Operating
	[°C]	-20 ~ +60	Storage
Surface Treatment	-	Anti-Glare	
Viewing Angle	[°]	90/50	
Color / Chromaticity Coordinates (CIE)	[x]	0.313*	+/-0.03
	[y]	0.329*	+/-0.03
Uniformity	[%]	80*	

\* based on engineer's estimation, and are subject to change w/o notice.



# Product Specification

AU OPTRONICS CORPORATION

## 2.2 Optical Characteristics

The optical characteristics are measured under stable conditions at 25 °C (Room Temperature) :

Item	Unit	Conditions	Min.	Typ.	Max.	Note
White Luminance ICCFL=6.5mA	[cd/m <sup>2</sup> ]		160	200	-	4
Viewing Angle	[degree]	Horizontal (Right)	-	45	-	1
		CR = 10 (Left)	-	45	-	
		Vertical (Upper)	-	15	-	
		CR = 10 (Lower)	-	35	-	
Luminance Uniformity	[%]	9 Points	70%	80%		2,3
CR: Contrast Ratio			240	400	-	4
Cross talk	[%]				4	5
Response Time	[msec]	Rising	-	5		4,6
		Falling	-	3		
		Rising + Falling		8		
Color / Chromaticity Coordinates (CIE 1931)		Red x	TBD	TBD	TBD	4
		Red y	TBD	TBD	TBD	
		Green x	TBD	TBD	TBD	
		Green y	TBD	TBD	TBD	
		Blue x	TBD	TBD	TBD	
		Blue y	TBD	TBD	TBD	
		White x	0.283	0.313	0.343	
		White y	0.299	0.329	0.359	
Flicker	[dB]		-		-20	7

Note 1. Definition of viewing angle

Viewing angle is the measurement of contrast ratio  $\geq 10$  and  $\geq 5$ , at the screen center, over a 180° horizontal and 180° vertical range (off-normal viewing angles). The 180° viewing angle range is broken down as follows; 90° ( $\theta$ ) horizontal left and right and 90° ( $\Phi$ ) vertical, high (up) and low (down). The measurement direction is typically perpendicular to the display surface with the screen rotated about its center to develop the desired measurement viewing angle.

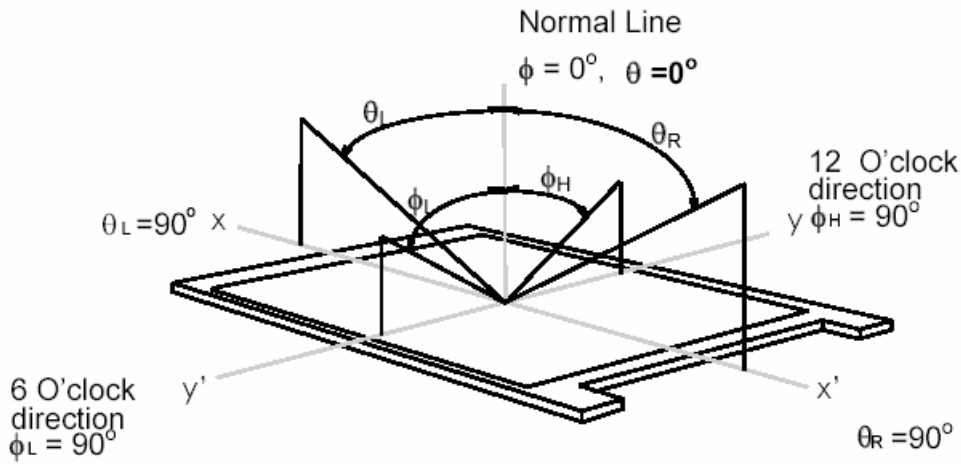

Note 2: 9 points position

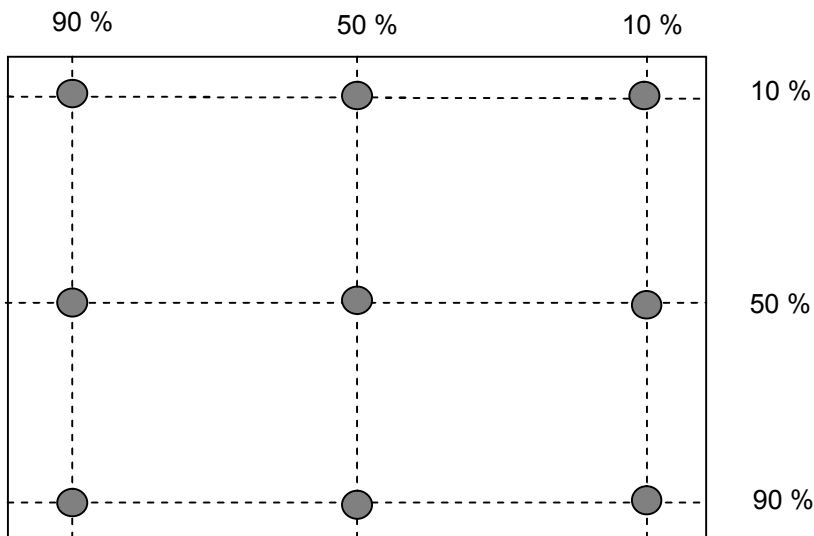

Note 3: The luminance uniformity of 9 points is defined by dividing the maximum luminance values by the minimum test point luminance

$$\delta_{w9} = \frac{\text{Minimum Brightness of 9 points}}{\text{Maximum Brightness of 9 points}}$$

Note 4: Measurement method

The LCD module should be stabilized at given temperature for 30 minutes to avoid abrupt temperature change during measuring. In order to stabilize the luminance, the measurement should be executed after lighting Backlight for 30 minutes in a stable, windless and dark room.

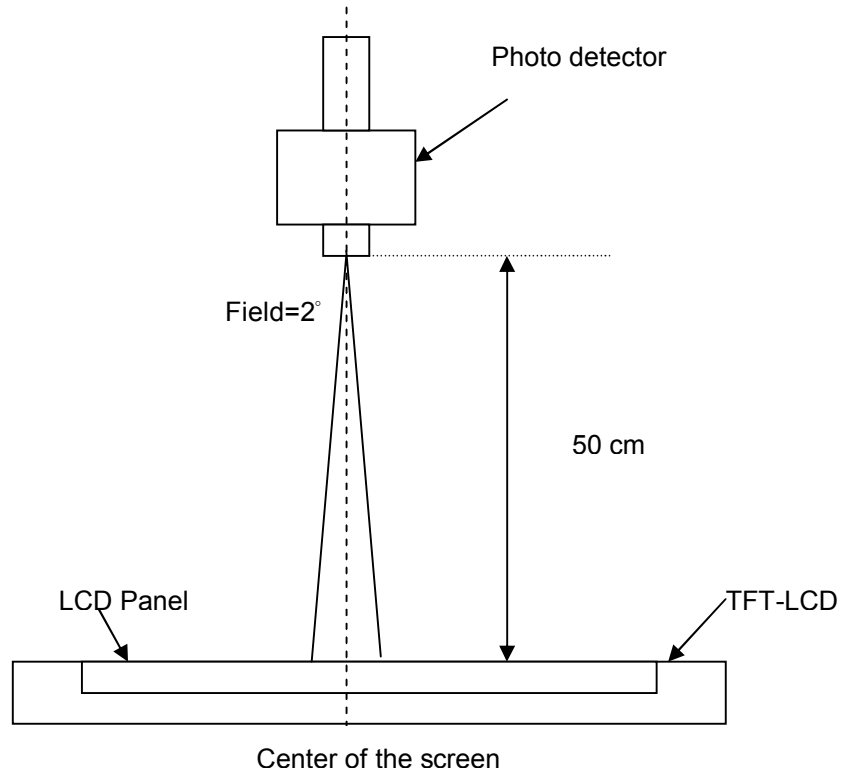

Note 5 : Definition of Cross Talk (CT)

$$CT = | Y_B - Y_A | / Y_A \times 100 (\%)$$

Where

$Y_A$  = Luminance of measured location without gray level 0 pattern ( $cd/m^2$ )

$Y_B$  = Luminance of measured location with gray level 0 pattern ( $cd/m^2$ )

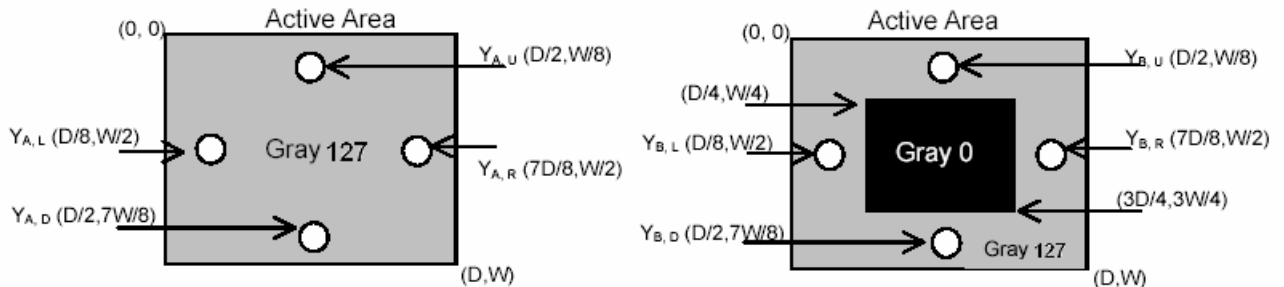

Note 6: Definition of response time:

The output signals of photo detector are measured when the input signals are changed from “Full Black” to “Full White” (rising time), and from “Full White” to “Full Black” (falling time), respectively. The response time is interval between the 10% and 90% of amplitudes. Please refer to the figure as below.

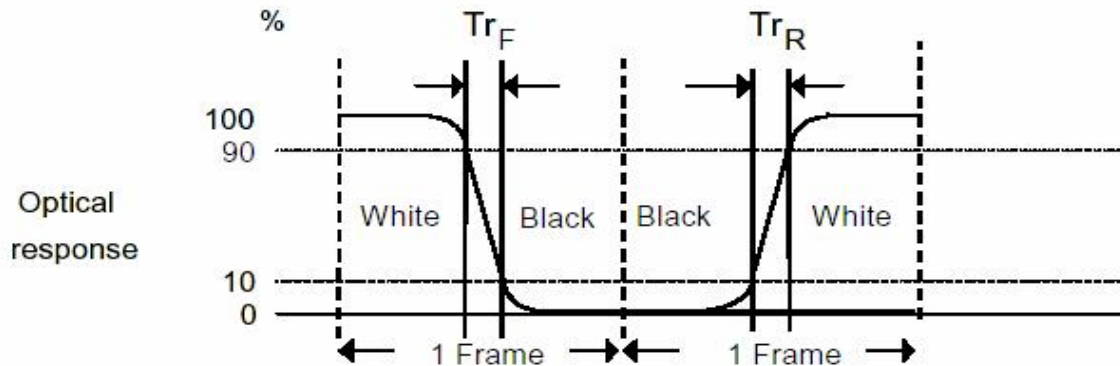

Note 7: Subchecker Pattern

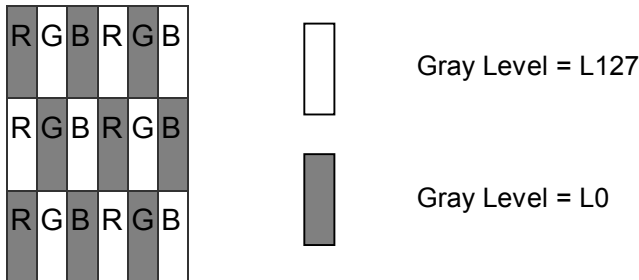

Method: Record dBV & DC value with (WESTAR)TRD-100

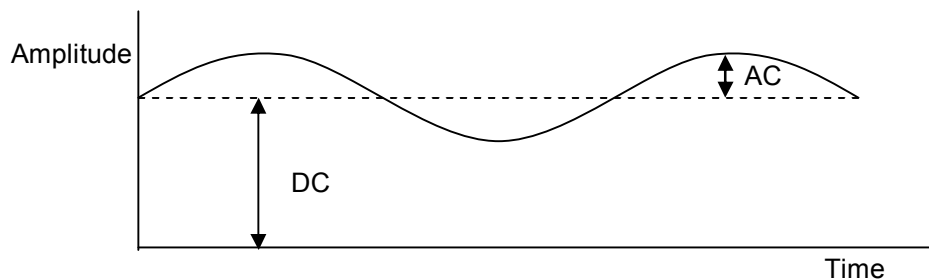

$$\text{Flicker (dB)} = 20 \log \frac{\text{AC Level(at 30 Hz)}}{\text{DC Level}}$$

## 3. Functional Block Diagram

The following diagram shows the functional block of the 15.4 inches wide Color TFT/LCD Module:

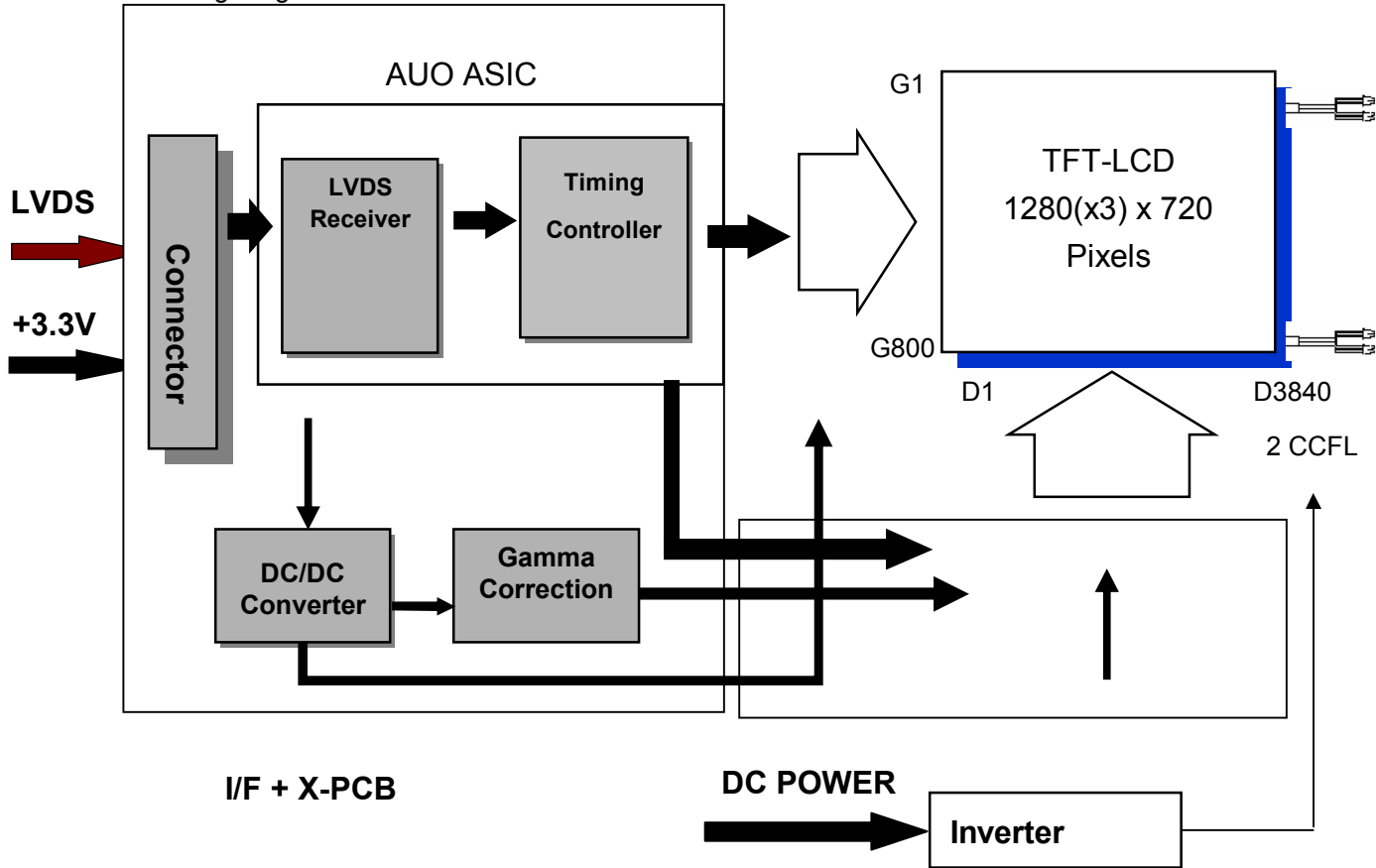

## 4. Absolute Maximum Ratings

Absolute maximum ratings of the module is as following:

### 4.1 Absolute Ratings of TFT LCD Module

Item	Symbol	Min	Max	Unit	Conditions
Logic/LCD Drive	Vin	-0.3	+4.0	[Volt]	Note 1,2

### 4.2 Absolute Ratings of Backlight Unit

Item	Symbol	Min	Max	Unit	Conditions
CCFL Current	ICCFL	-	7.5	[mA] rms	Note 1,2

### 4.3 Absolute Ratings of Environment

Item	Symbol	Min	Max	Unit	Conditions
Operating	TOP	0	+50	[°C]	Note 3
Operation Humidity	HOP	5	90	[%RH]	Note 3
Storage	TST	-20	+60	[°C]	Note 3
Storage Humidity	HST	5	90	[%RH]	Note 3

Note 1: At Ta (25°C )

Note 2: Permanent damage to the device may occur if exceed maximum values

Note 3: For quality performance, please refer to AUO IIS(Incoming Inspection Standard).

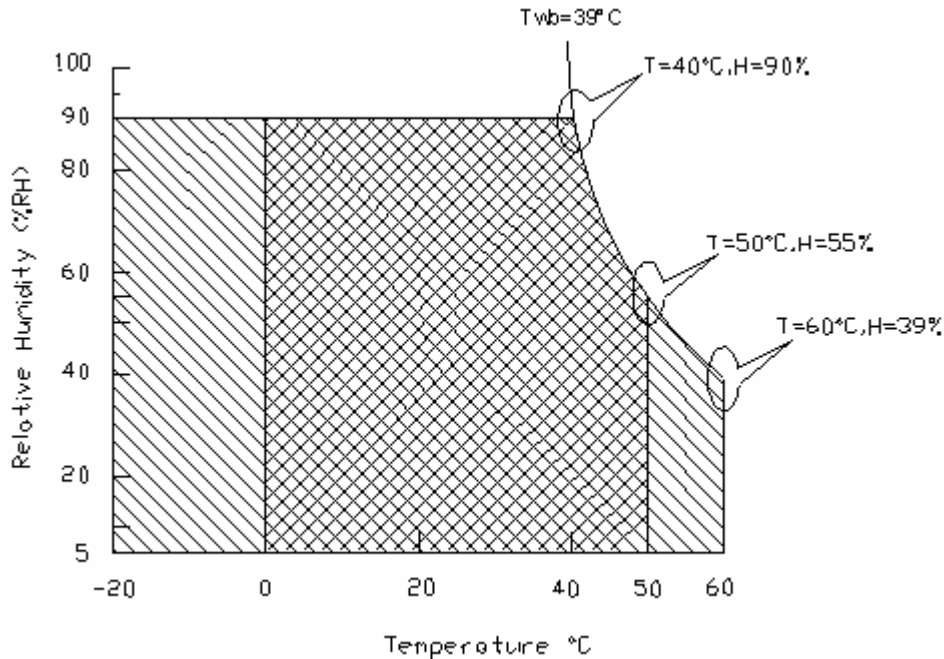

Operating Range



Storage Range

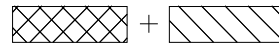

## 5. Electrical characteristics

### 5.1 TFT LCD Module

#### 5.1.1 Power Specification

Input power specifications are as follows:

Symbol	Parameter	Min	Typ	Max	Units	Note
VDD	Logic/LCD Drive Voltage	3.0	3.3	3.6	[Volt]	
PDD	VDD Power			TBD	[Watt]	Note 1
IDD	IDD Current		350	450	[mA]	Note 1
IRush	Inrush Current			2000	[mA]	Note 2
VDDrp	Allowable Logic/LCD Drive Ripple Voltage			100	[mV] p-p	

Note 1 : Maximum Measurement Condition : Black Pattern

Note 2 : Measure Condition

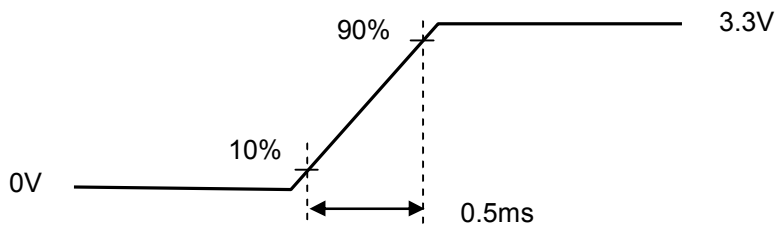
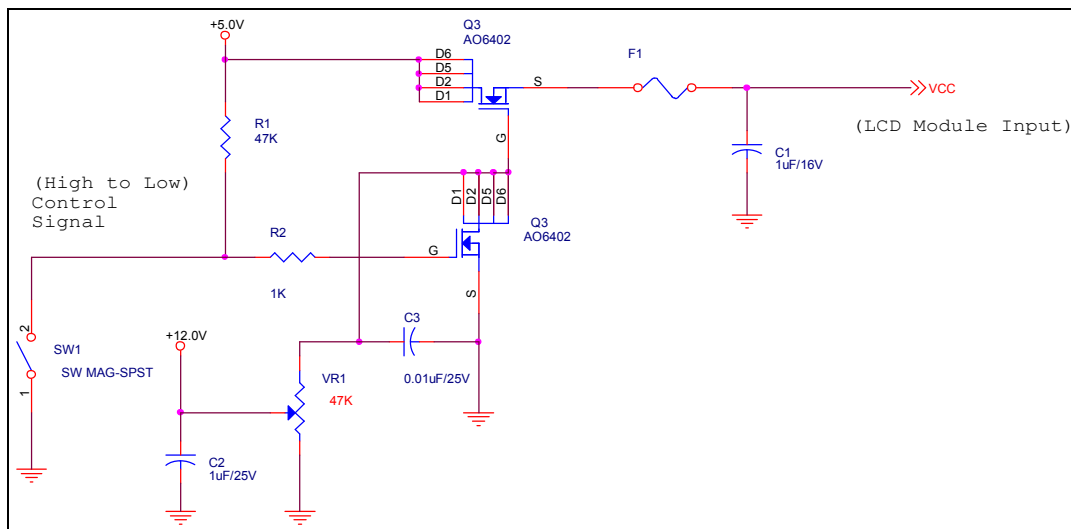

Vin rising time

## 5.1.2 Signal Electrical Characteristics

Input signals shall be low or High-impedance state when VDD is off.

It is recommended to refer the specifications of THC63LVDF84A(Thine Electronics Inc.) in detail.

Signal electrical characteristics are as follows:

Parameter	Condition	Min	Max	Unit
Vth	Differential Input High Threshold (Vcm=+1.2V)		100	[mV]
Vtl	Differential Input Low Threshold (Vcm=+1.2V)	-100		[mV]
Vcm	Differential Input Common Mode Voltage	1.125	1.375	[V]

Note: LVDS Signal Waveform

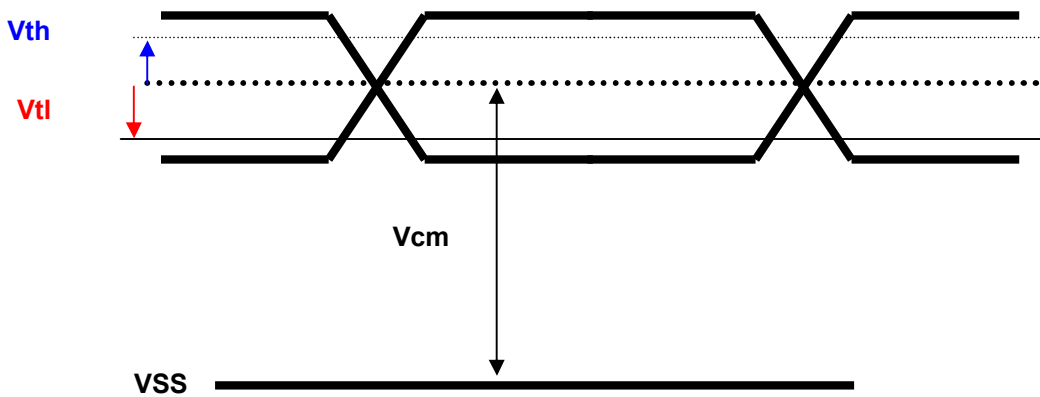

## 5.2 Backlight Unit

Parameter guideline for CCFL Inverter is under stable conditions at 25 °C (Room Temperature) :

Parameter	Min	Typ	Max	Units	Condition
CCFL Standard Current (I <sub>SCFL</sub> )	7.0	7.5	8.0	[mA] rms	Note 2
CCFL Operation current (I <sub>RCFL</sub> )	3.0	8.0	8.0	[mA] rms	
CCFL Frequency (F <sub>CFL</sub> )	40	50	80	[KHz]	Note 3,4,8
CCFL Ignition Voltage (V <sub>icFL</sub> , Ta= 0°C)				[Volt] rms	Note 5
CCFL Ignition Voltage (V <sub>icFL</sub> , Ta= 25°C)				[Volt] rms	
CCFL Voltage (V <sub>CFL</sub> )				[Volt] rms	Note 6
CCFL Power consumption (P <sub>CFL</sub> )				[Watt]	Note 6

CCFL Life Time (LT <sub>CCFL</sub> )	40,000	50,000	-	[Hour]	Note 7
--------------------------------------	--------	--------	---	--------	--------

Note 1: Typ. are AUO recommended design points.

- \*1 All of characteristics listed are measured under the condition using the AUO test inverter.
- \*2 In case of using an inverter other than listed, it is recommended to check the inverter carefully. Sometimes, interfering noise stripes appear on the screen, and substandard luminance or flicker at low power may happen.
- \*3 In designing an inverter, it is suggested to check safety circuit very carefully. Impedance of CCFL, for instance, becomes more than 1 [M ohm] when CCFL is damaged.
- \*4 Generally, CCFL has some amount of delay time after applying kick-off voltage. It is recommended to keep on applying ignition voltage for 1 [Sec] until discharge.
- \*5 Reducing CCFL current increases CCFL discharge voltage and generally increases CCFL discharge frequency. So all the parameters of an inverter should be carefully designed so as not to produce too much leakage current from high-voltage output of the inverter.

Note 2: It should be employed the inverter which has “Duty Dimming”, if I<sub>RCFL</sub> is less than 3mA.

Note 3: CCFL discharge frequency should be carefully determined to avoid interference between inverter and TFT LCD.

Note 4: The frequency range will not affect to lamp life and reliability characteristics.

Note 5: CCFL inverter should be able to give out a power that has a generating capacity of over 1290 voltage. Lamp units need 1290 voltage minimum for ignition.

Note 6: The variance of CCFL power consumption is ±10%. Calculator value for reference (I<sub>SCFL</sub> × V<sub>CFL</sub> × 2 = P<sub>CFL</sub>)

Note 7: Definition of life: brightness becomes 50%. The typical life time of CCFL is under the condition at 6.5 mA lamp current.

Note 8: Requirement for system inverter design, which is intended to have a better display performance, a better power efficiency and a more reliable lamp. It should help increase the lamp lifetime and reduce its leakage current.

The frequency range will not affect to lamp lifetime and reliability characteristics. (Reference value)

The rate of unsymmetrical of lamp lighting waveform is shown (Lamp current waveform and lamp voltage waveform) at 5% or less.

$$\text{Asymmetrical} : ( | A | - | B | ) / | C | \leq 5 \%$$

A : Lamp current or lamp voltage o-p of +side

B : Lamp current or lamp voltage o-p of -side

C : Max(A,B) this is bigger in A or B

Recommendation lighting frequency : 50 ~ 60 KHz

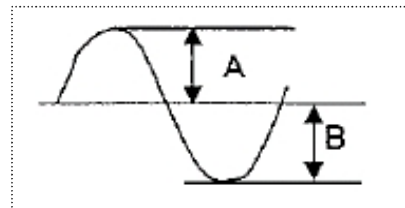

## 7. Connector Description

Physical interface is described as for the connector on module.

These connectors are capable of accommodating the following signals and will be following components.

### 7.1 TFT LCD Module

Connector Name / Designation	For Signal Connector
Manufacturer	JAE or compatible
Type / Part Number	TBD
Mating Housing/Part Number	TBD

### 7.2 Backlight Unit

Physical interface is described as for the connector on module.

These connectors are capable of accommodating the following signals and will be following components.

Connector Name / Designation	For Lamp Connector
Manufacturer	CviLux
Type / Part Number	CP0502SL09
Mating Type / Part Number	CP0502P1ML0-LF

### 7.3 Signal for Lamp connector

	Connector No.	Pin No.	Input	Color	Function
Upper	CN1	1	Hot1	Pink	High Voltage
		2	Cold1	White	Low Voltage

	Connector No.	Pin No.	Input	Color	Function
Lower	CN2	1	Hot1	Pink	High Voltage
		2	Cold1	White	Low Voltage

## 8. Reliability Test

Items	Required Condition	Note
Temperature Humidity Bias (THB)	Ta= 50°C, 80%RH, 300hours	
High Temperature Operation (HTO)	Ta= 50°C, 50%RH, 300hours	
Low Temperature Operation (LTO)	Ta= 0°C, 300hours	
High Temperature Storage (HTS)	Ta= 60°C, 300hours	
Low Temperature Storage (LTS)	Ta= -20°C, 300hours	
Vibration Test (Non-operation)	Acceleration: 1.5 G Wave: Random Frequency: 10 - 200 - 10 Hz Sweep: 30 Minutes each Axis (X, Y, Z)	
Shock Test (Non-operation)	Acceleration: 50 G Wave: Half-sine Active Time: 20 ms Direction: ±X, ±Y, ±Z (one time for each Axis)	
Drop Test	Height: 60 cm, package test	
Thermal Shock Test (TST)	-20°C/30min, 60°C/30min, 100 cycles	1
On/Off Test	On/10sec, Off/10sec, 30,000 cycles	
ESD (Electro Static Discharge)	Contact Discharge: ± 8KV, 150pF(330Ω ) 1sec, 8 points, 25 times/ point.	2
	Air Discharge: ± 15KV, 150pF(330Ω ) 1sec 8 points, 25 times/ point.	
Altitude Test	Operation:10,000 ft Non-Operation:30,000 ft	

Note 1: The TFT-LCD module will not sustain damage after being subjected to 100 cycles of rapid temperature change. A cycle of rapid temperature change consists of varying the temperature from -20°C to 60°C, and back again. Power is not applied during the test. After temperature cycling, the unit is placed in normal room ambient for at least 4 hours before power on.

Note 2: According to EN61000-4-2, ESD class B: Some performance degradation allowed. No data lost. Self-recoverable. No hardware failures.

## PIN Assignment

Pin No.	Symbol	Function	Pin No.	Symbol	Function
1	VDD	3.3V	11	RXIN2-	LVDS Signal
2	VDD	3.3V	12	RXIN2+	LVDS Signal
3	VSS	Ground	13	VSS	Ground
4	VSS	Ground	14	RXCLK-	LVDS Signal
5	RXIN0-	LVDS Signal	15	RXCLK+	LVDS Signal
6	RXIN0+	LVDS Signal	16	VSS	Ground
7	VSS	Ground	17	RXIN3-	LVDS Signal
8	RXIN1-	LVDS Signal	18	RXIN3+	LVDS Signal
9	RXIN1+	LVDS Signal	19	AGMODE	Active High/Ground
10	VSS	Ground	20	HVS	Active High/Ground

